

phyFLEX[®]-i.MX 8M Plus FPSC

FPSC soldering module for sophisticated and future-proof embedded designs

Based on the NXP i.MX 8M Plus SoC from NXP Semiconductors, the phyFLEX-i.MX 8M Plus is PHYTEC's "smartest" module. It is available in three versions: as a DSC solder module, as a plug-in module, and as a standard module in the FPSC version.

Equipped with up to 4 Cortex-A53, one Cortex-M7 for real-time applications, as well as a unique combination of a variety of multimedia interfaces with a powerful NPU (Neural Processing Unit), the phyFLEX-i.MX 8M Plus is ideal for machine learning (ML), image processing, advanced multimedia and industrial IoT applications.

The scalable and size-optimized phyFLEX-i.MX 8M Plus is the perfect basis for utilizing all the i.MX 8M Plus features in areas where intelligent and fast processing of multimedia data in the smallest possible space is required. Be it in the smart home (e.g., home automation), smart city (e.g., people/traffic monitoring), Industry 4.0 (e.g., intelligent robot control, HMI), or IIoT applications (e.g., edge computing). The FPSC version is particularly attractive: It is size-optimized and features sophisticated armature soldering technology for maximum production yield. Thanks to its FPSC design, the phyFLEX-i.MX 8M Plus FPSC is compatible with all existing and future modules of the FPSC 24.0 standard.

i.MX 8M Plus Processor

- Quad-core 1,8GHz Cortex-A53 processor
- On-chip image signal processor (up to 12 MP, 375 MP/s)
- Neural network accelerator up to 2,3 TOPS
- Thanks to FPSC, pin compatible with all other FPSC SoMs

Module Features

- Easy soldering using FTGA soldering technology
- Sophisticated energy management
- Fully TSN-capable Ethernet
- Selectable IO voltage between 1,8 V or 3,3 V.
- All processor interfaces are available on the SOM connection

Your Advantages

- Ready adapted Linux[®] operating system
- Only one device design for different performance configurations
- Product Life-Cycle Management program
- Global Technical Support



<https://www.phytec.de/produkte/system-on-modules/phyflex-imx-8m-plus-fpsc/>

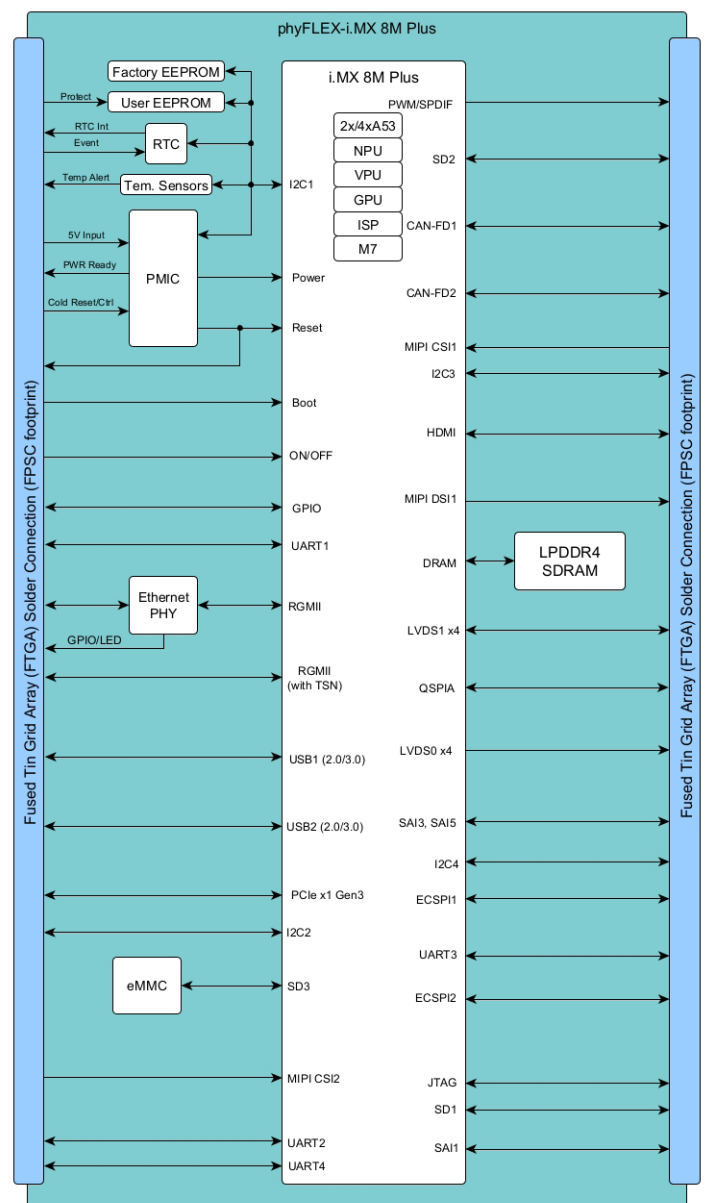
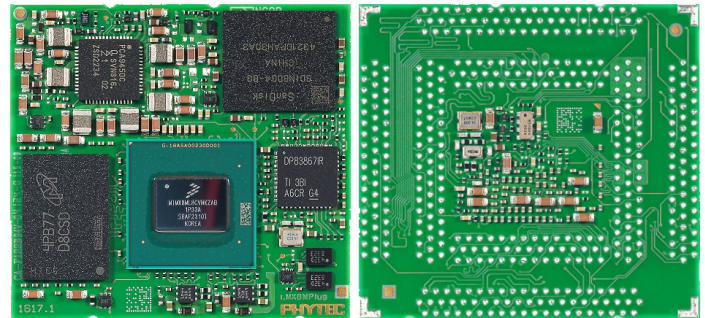

Technical Data

Module Configuration

Processor	NXP i.MX 8M Plus
Core	up to 4x Arm® Cortex®-A53
Additional Core	Arm® Cortex®-M7
Clock frequency	up to 1.8 GHz (A53), 800 MHz (M7)
L1 Cache	32kB Instruction Cashe 32kB Data Cashe
L2 Cashe	512 kB unified Cashe
Graphics	D GPU (2 shader, 16 GFLOPs GC7000UL OpenCL/GL/Vulkan), 2D GPU (GC520)
Video Processing	1080p60 H.265/4 Decode and Encode
ISP	up to 12MP resolution/ up to 375MP/s
NPU	up to 2.3TOPS
Crypto	RDC, CAAM, PKHA, RSA, EEC, RTIC, DRM, RSA, AES, 3DES, DES, RNG
HW Security	Secure boot, TrustZone, SNVS, SRTC, SJC
EXT. MEMORY	
eMMC	4 GB up to 64 GB eMMC 5.1
DDR4	256 MB up to 8 GB (32 Bit)
EEPROM	4 kB - 32 kB (User EEPROM) + 4 kB (Fac- tory EEPROM)

PHYSICAL PROPERTIES

Dimensions	40 mm x 37 mm x 3 mm
Weight	tbd.
Operating temperature	-40 °C to +85 °C
Humidity	95 % RH non condensing
Operating voltage	5.0 V
Power consumption typ.	tbd.
PCB connection	FTGA with FPSC–Gamma 1.1 footprint, 1.27 mm pitch

SOFTWARE

Operating system	Linux (Yocto based)
------------------	---------------------

Module Interfaces

Ethernet	2x 10/100/1000 Mbit/s (1x TSN Support)
USB	2x USB 3.0, 2x USB 2.0 OTG
UART	4x
CAN	up to 2x CAN FD
PCIe	1x (Gen 3)
I²C	up to 3x
SPI	3x ECSPi (+1x QSPI)
MMC/SD/SDIO	up to 2x
ePWM	up to 4x, 6x Timer
Display	Dual LVDS (2 x 4 Lanes), MIPI DSI-2, HDMI
Camera	2x MIPI CSI-2
Audio	SAI, SPDIF, I2S, AC'97, TDM
ADC	up to 4 (10-bit)
Debugging	UART, JTAG

* Due to multiplexing, not all interfaces may be fully available.

** Due to the exclusive use of individual interfaces on the module, the maximum number may differ from the processor specification.

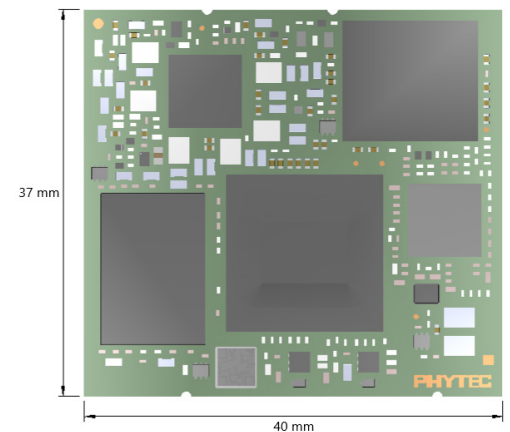

Libra Development Board FSPC

Versatile Development Platform for FPSC Modules

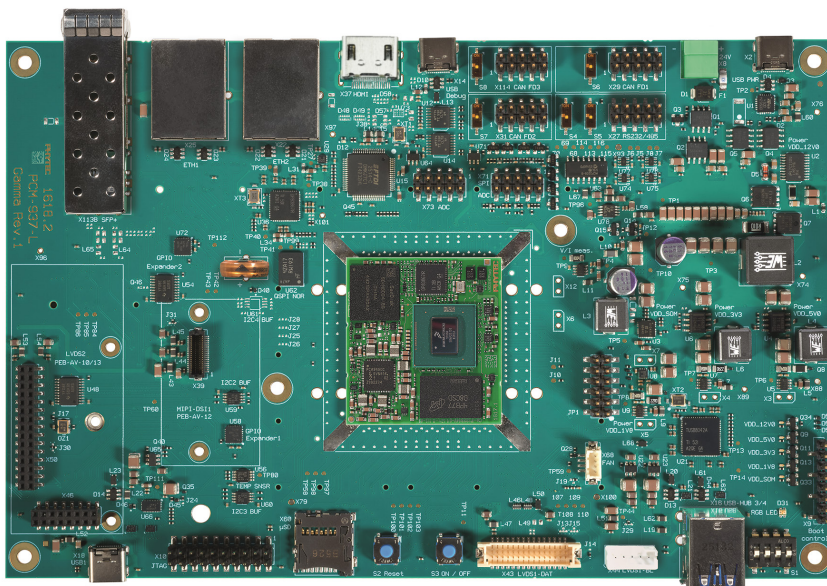

INTERFACES

Ethernet	2x 1 GbE (all RJ45) (TSN support)
USB	1x USB 2.0 (Type-A), 1x USB 2.0 (Type-C)
Serial	1x RS-232 or RS-485, 2x CAN FD (3x pin header 2x5)
Display	1x LVDS
Debugging	JTAG (Expansion sockets) 1x USB 2.0 Debug (Type-C)
Various	I²C, SPI, GPIO, ADC (Expansion connectors)

MISCELLANEOUS

MMC/SD/SDIO	microSD Card Slot
User Control	3x LED, 1x RGB LED, 2x button
Dimensions	230 mm x 140 mm
Supply Voltage	24 V or USB-C