

phyBOARD®-Nash i.MX 93

Get your phyBOARD-Nash powered up and connected in just a few simple steps.

1 | PREPARING THE HARDWARE

1. Have your connection cables at hand: You need a USB C to USB A cable (one-to-one) and a standard Ethernet cable. Phytect offers an accessory kit which includes these cables
2. Power up the phyBOARD-Nash i.MX 93. Connect the pin PHOENIX connector (included) to a 12 V-24 V ($\pm 10\%$) DC power supply. Note the polarity of the connectors (see **picture A**)! If you are using the included power supply with your kit, it is already wired with the 2-pin connector. Turn on your power supply and plug the 2-pin PHOENIX connector into the green jack on your kit (**X49**).
3. The Power LED **D30** will light up.

Kit Contents

phyBOARD-Nash i.MX93

Power Adapter +24 V

USB flash drive with Virtual Machine



RS-232 and CAN Adapter

Ethernet Cable



12 V-24 V-kit version



2-pin PHOENIX

USB-A to USB-B

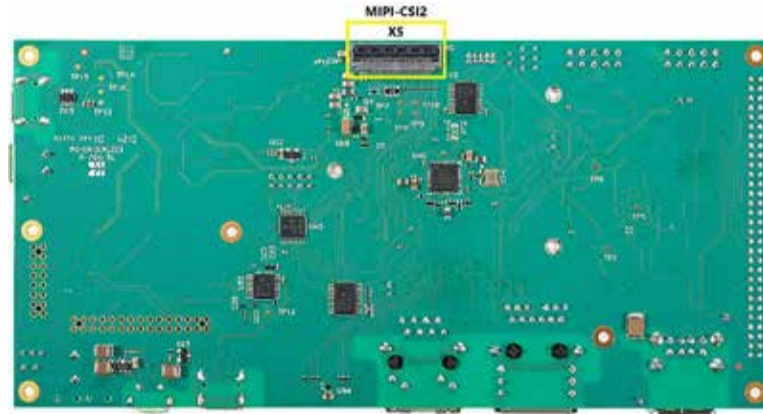

Figure 1: Boot Mode DIP Switch (S3)
SD Card Setting



phyBOARD-Nash
with phyCORE-i.MX 93

FRONT - CONNECTORS



BOTTOM

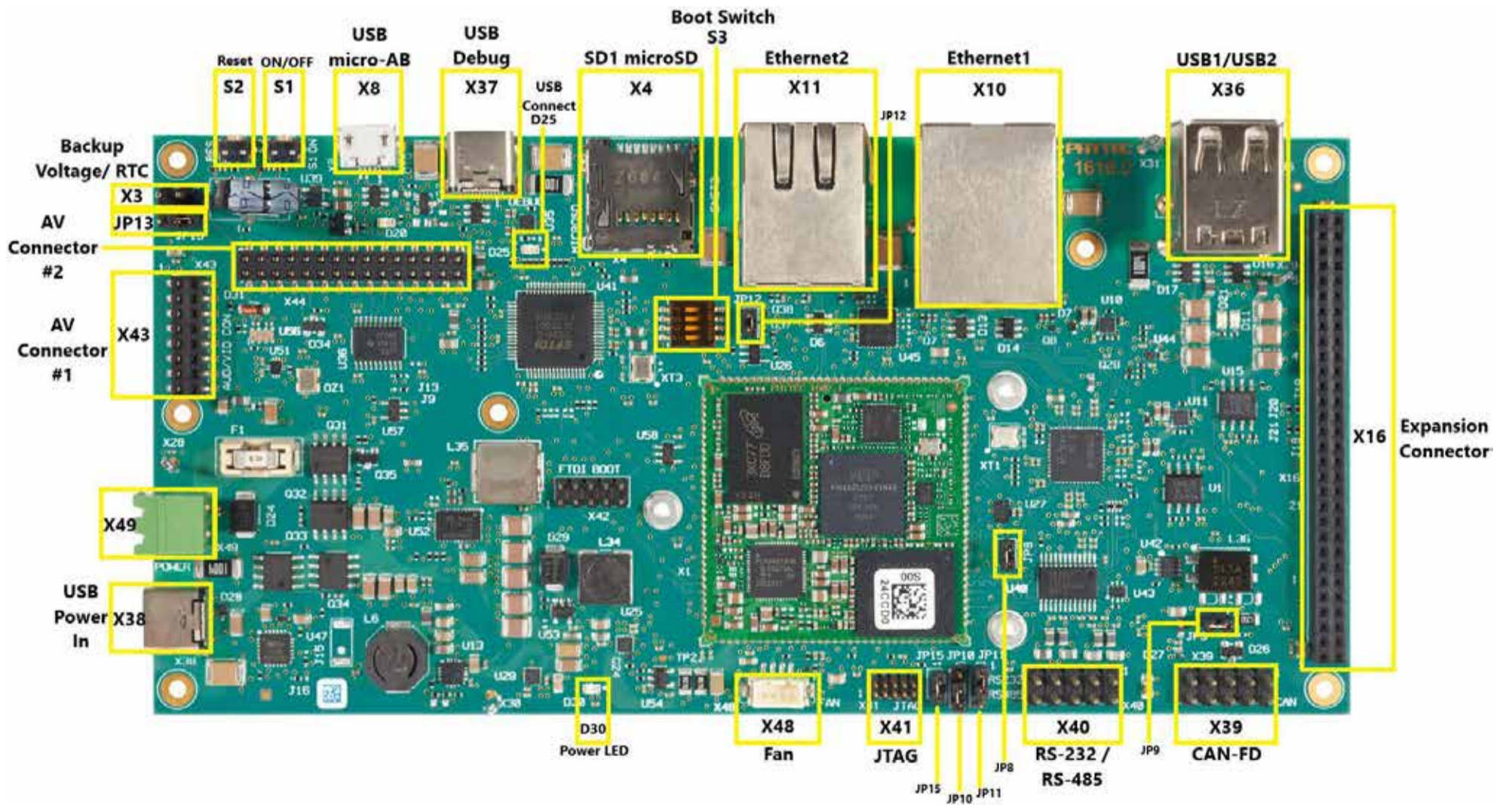

PHYTEC

Germany
PHYTEC Messtechnik GmbH
D-55129 Mainz
t +49 6131 9221-32
f +49 6131 9221-33
www.phytec.de
www.phytec.eu

France
PHYTEC France SARL
F-72140 Sillé le Guillaume
t +33 2 43 29 22 33
f +33 2 43 29 22 34
www.phytec.fr

USA
PHYTEC America LLC
Bainbridge Island, WA 98110
t +1 206 780 9047
f +1 206 780 9135
www.phytec.com

India
PHYTEC Embedded Pvt. Ltd.
Bangalore
560102
t +91 80 40867046
www.phytec.in

China
PHYTEC Information Technology Co. Ltd.
Nanshan District
518052 Shenzhen
t +86 755 6180 2110
www.phytec.cn

L-107/te-A1

Quick Start Guide

2 | PREPARING AND STARTING THE VIRTUAL MACHINE

Experienced developers working with native Linux which have experience with Yocto development may skip the VM setup and proceed directly to Section 3 for establishing a direct connection to the PHYTEC-Board from their Linux host system.

The virtual machine provides a pre-configured development environment with all necessary tools and configurations (including Toolchain, Eclipse, and Qt Creator) for developing with your PHYTEC-Board. To get started, you'll need a virtualization software like Virtual-Box or VMware Player.

1. Obtain the virtual machine image (OVA and checksum files) from the provided USB stick or the download section of your specific product at PHYTEC's website.
2. Import the .ova file into your virtualization software.
3. Launch the virtual machine. You'll be presented with a modified Ubuntu desktop.

Username: phym

Password: phytec

Performance Configuration of the Virtual Machine

The virtual machine is configured to use 2 CPU cores and 2 GB of RAM by default. You can adjust these settings in your virtualization tool's configuration to improve performance, which is particularly important when running Yocto-Builds.

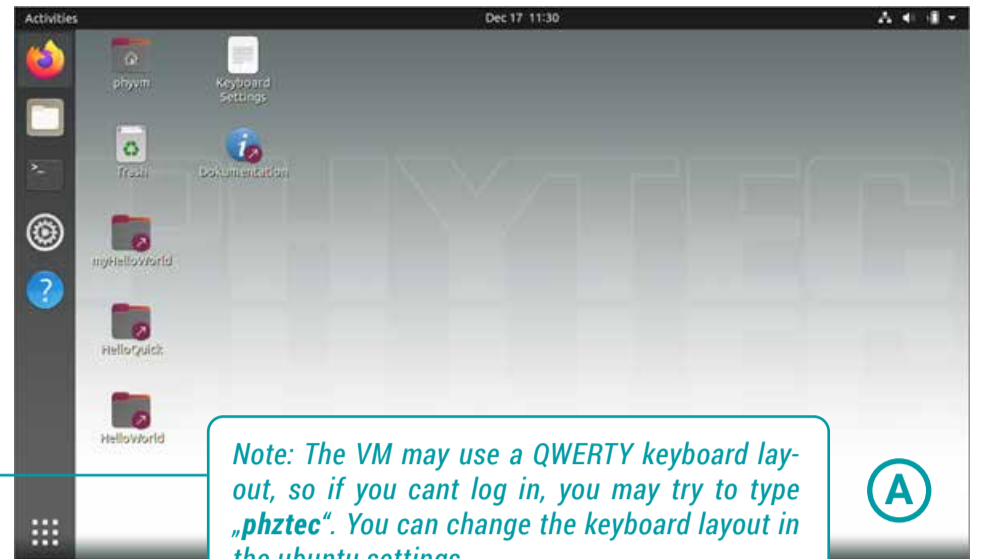

3 | GETTING CONNECTED

SERIAL CONNECTION

1. Insert the provided SD card into the PHYTEC-Board
2. Connect the USB-A to USB-C Cable to your PC and to the USB Debug Port (X37) on the PHYTEC-Board. When using the virtual machine, ensure the USB device is properly passed through to the virtual machine.
3. Open a terminal (within the virtual machine or your Linux host-system) and enter the command „**tio /dev/ttyUSB0**“. You should then see the message “Connected” (B)
4. Power cycle the board. Within a few seconds, you'll see the boot message and login prompt on the console. (C)
5. Use „**root**“ as the login name on the serial console and press enter. You are now successfully connected to the board and ready to go. (C)
6. You can now enter „**ip a**“ to view the configuration of the target's Ethernet interface. This will be helpful for the next optional step. (D)

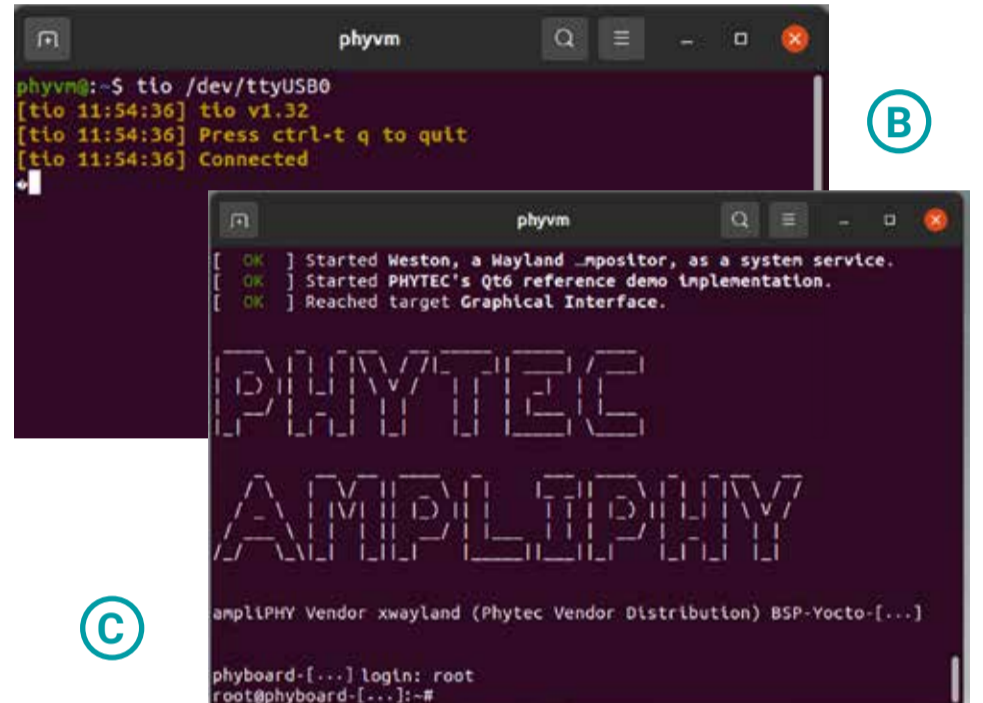

ETHERNET CONNECTION

Setting up an Ethernet connection is optional but recommended for faster development. While the UART connection works well for basic tasks, an SSH connection over Ethernet provides better performance, especially useful for file transfers and development tasks. For the setup, you'll need a network adapter on your host PC to connect to the PHYTEC-Board. We recommend having a second network adapter for internet access, as this allows you to simultaneously work with the board and access online resources.

The PHYTEC-Board comes with a pre-configured static IP address (192.168.3.10) for peer-to-peer connection, but the board can also obtain an additional IP address via DHCP. You can view the DHCP-assigned IP address through the UART connection using the „ip a“ command. (D)

PEER-TO-PEER CONNECTION

1. Connect an Ethernet cable between your PC and the board's ETH2 port X11.
2. Navigate to the Network Configuration on your host system (e.g. Windows). Choose the ethernet connection to the PHYTEC-Board and configure it with these IPv4 settings: **IP Address: 192.168.3.10**
Subnet Mask: 255.255.255.0
Gateway: 192.168.3.10
3. Open a terminal (from your host system or within the VM) and connect to the board with the command „**ssh root@192.168.3.11**“. You should now see an authentication question. Type „**yes**“ and press Enter.

You are now connected to your PHYTEC-Board. Congratulations!

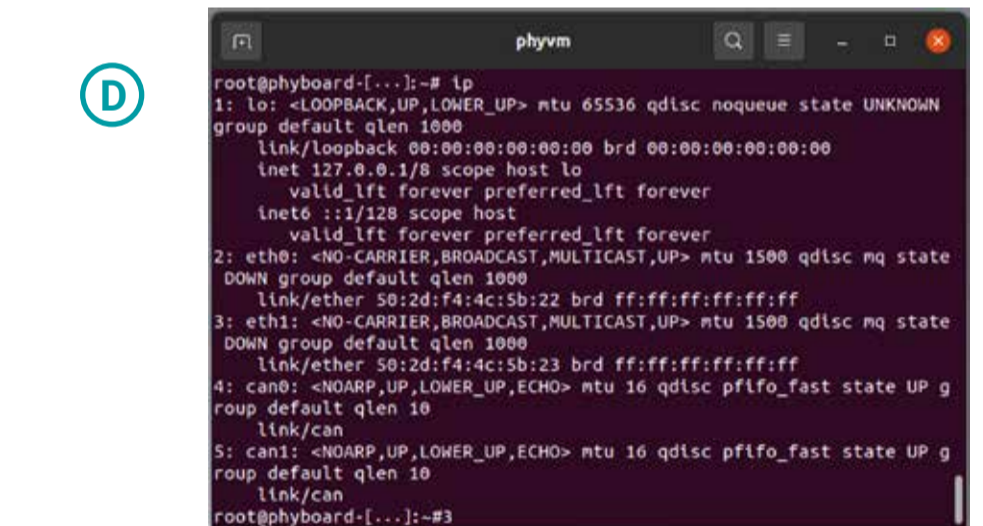

4 | YOUR POSSIBLE NEXT STEPS

Visit the product page of your specific product for the latest documentation, downloads & FAQs:

<https://www.phytec.eu/en/produkte/single-board-computer/>



The download section contains several essential guides.

We recommend starting with the **Development Environment Guide**, as this covers:

- Comprehensive instructions for working with PHYTEC's pre-configured virtual machine
- Setting up a native Linux development environment if you don't work with the VM
- Cross-compiling your first applications using Eclipse and first steps on GUI development with the pre-installed Qt Creator

ADDITIONAL DOCUMENTATION AVAILABLE IN THE DOWNLOAD SECTION

Hardware Manual:

A detailed description of the System on Module and accompanying carrierboard.

Yocto Guide: Reference for working with the PHYTEC BSP, including detailed information about Yocto Project fundamentals, BSP customization procedures, and practical workflows with tools like Poky and Bitbake.

BSP Manual: Focuses specifically on the phyCORE's BSP implementation, covering essential topics like build processes, boot procedures, software updates, device tree configurations, and peripheral access methods.

Please feel free to contact our support team if you have any questions about getting the board up and running.

<https://www.phytec.de/support/help-desk/>

