

TABLE of CONTENTS

ISOLATION TRANSFORMERS

10BASE-T

Electrical Specifications: Surface Mount and Through Hole	2
---	---

ETHERNET

Electrical Specifications: Surface Mount and Through Hole	3
---	---

APPLICATION CIRCUITS

10Base-T	4
Ethernet	5

SCHEMATICS	6
-------------------------	---

MECHANICALS

Surface Mount	8
Through Hole	10

ISOLATION TRANSFORMERS FOR 10BASE-T

For Adapter Cards, MAUs, Hubs, and Motherboard Applications



- Designed to meet or exceed IEEE 802.3, 10Base-T specifications
- Available with common mode chokes for EMI suppression
- Surface mount, IC grade, transfer-molded package withstands 235°C peak temperature profile
- Through hole, auto-insertable, 16-pin DIP package

Electrical Specifications @ 25°C — Operating Temperature 0°C to 70°C

Part Number	Turns Ratio (±5%)		Primary Pins	Common Mode Choke	Sine Wave Inductance OCL ¹ (μH MIN)	Interwinding Capacitance C _{ww} ¹ (pF MAX)	Leakage Inductance L _L ¹ (μH MAX)	DCR (Ω MAX)	Hi-Pot (Vrms)	Schem.	Mech.
	Transmit	Receive									
SURFACE MOUNT²										pp. 6-7	pp. 8-9
PE-65454	1:√2	1:1	3-4/1-2		140	12	0.2	0.4	2000	T1	SMT2
E5017	1CT:1CT	1CT:1CT	1-3/6-8	X	200	10	0.25	1.0	1500	T6	SMT4
PE-65726	1CT:1CT	1CT:1CT	1-3/6-8		200	10	0.2	0.3	2000	T4	SMT4
23Z114SM	1CT:1CT	1CT:1CT	1-3/6-8		200	12	0.3	0.3	2000	T4	SMT5
PE-68048	1CT:√2CT	1CT:1CT	6-8/1-3	X	110	15	0.4	1.0	1500	T5	SMT4
PE-65745	1CT:√2CT	1CT:1CT	6-8/1-3		140	12	0.2	0.3	2000	T4	SMT4
23Z128SM	1CT:√2CT	1CT:1CT	6-8/1-3		200	15	0.5	0.4	2000	T4	SMT5
23Z356SM	1CT:√2CT	1CT:1CT	6-8/1-3	X	200	12	0.5	0.6	2000	T7	SMT5
23Z435SM	2CT:1CT	1CT:1CT	1-3/6-8		100	10	0.4	0.5	2000	T4	SMT5
PE-68052	2CT:1CT	1CT:1CT	1-3/6-8	X	140	12	0.3	1.0	1500	T6	SMT4
E4001	1CT:2CT	1CT:1CT	6-8/1-3	X	112	8	0.3	0.8	1500	T5	SMT4
PE-68041	1CT:2CT	1CT:1CT	6-8/1-3		112	8	0.3	0.5	1500	T4	SMT4
23Z467SM	1CT:2CT	1CT:1CT	6-8/1-3	X	140	12	0.1	0.6	2000	T7	SMT5
PE-68023	1CT:2CT	1CT:1CT	1-3/6-8	X	200	12	0.3	1.0	1500	T6	SMT4
PE-68042	2√2CT:1	1:1	2-4/7-9		200	14	1	0.5	1500	T9	SMT1
PE-68810	—	1:1 (4X)	1-2/3-4		140	12	0.2	0.4	2000	T3	SMT4
PE-68820	1:√2 (4X)	—	1-2/3-4 5-6/7-8		140	12	0.2	0.4	2000	T3	SMT4
THROUGH HOLE										pp.6-7	p. 10
23Z435	2CT:1CT	1CT:1CT	1-3/6-8		80	10	0.4	0.5	2000	T4	TH3
23Z128	1CT:√2CT	1CT:1CT	6-8/1-3		140	15	0.5	0.4	2000	T4	TH3
PE-65263	1CT:1CT	1CT:1CT	1-3/6-8		200	15	0.25	0.3	2000	T4	TH4

NOTES:

1. OCL, C_{ww} and L_L are measured at 20 mVrms, 100 KHz.

2. To order Tape & Reel packaging for surface mount parts, add the suffix "T" to the part number (Example: PE-65454T). The "T" will appear on all paper work, but will not be marked on parts.

ISOLATION TRANSFORMERS FOR ETHERNET

AUI Transformers

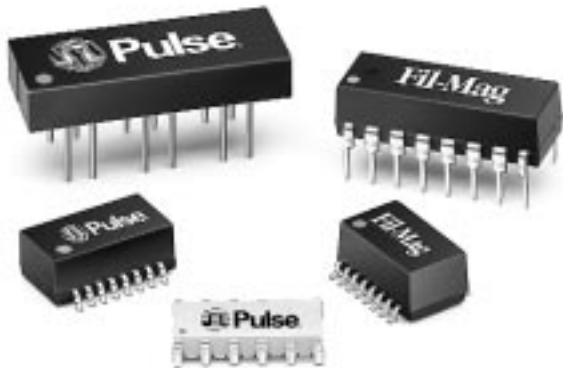

- ⊕ Low leakage inductance and coupling capacitance for faster rise times
- ⊕ Small form factor, 50 mil lead spacing
- ⊕ Through hole, auto-insertable, 16-pin DIP package

Electrical Specifications @ 25°C — Operating Temperature 0°C to 70°C

Part Number	Turns Ratio (±5%)	Primary Pins	Primary Sine Wave OCL ¹ (μH ±20%)	Primary ET-Constant (V-μs MIN)	Rise Time ² (ns MAX)	Interwinding Capacitance C _{ww} ¹ (pF MAX)	Leakage Inductance L _L ¹ (μH MAX)	DCR (Ω MAX)	Schem.	Mech.	Hipot (Vrms)
SURFACE MOUNT³									pp. 6-7	pp. 8-9	
E6002	1:1	1-2/4-5/7-8	40 (MIN)	2.1	3.0	8	0.20	0.25	T2	SMT4	2000
PE-65723	1:1	1-2/4-5/7-8	75	1.8	3.0	8	0.20	0.30	T2	SMT4	2000
PE-68801	1:1	1-2/3-4/5-6	75	1.8	3.0	12	0.20	0.30	T8	SMT3	2000
23Z90SM	1:1	1-2/4-5/7-8	75	2.4	3.0	10	0.20	0.20	T2	SMT5	2000
PE-65728	1:1	1-2/4-5/7-8	100	1.8	3.0	9	0.20	0.30	T2	SMT4	2000
23Z91SM	1:1	1-2/4-5/7-8	100	2.4	3.0	10	0.20	0.30	T2	SMT5	2000
PE-65727	1:1	1-2/4-5/7-8	150	1.2	3.0	12	0.20	0.30	T2	SMT4	2000
PE-65733	1:1	1-2/4-5/7-8	350	2.6	3.5	16	0.30	0.35	T2	SMT4	2000
23Z108SM	1:1	1-2/4-5/7-8	350	2.5	3.5	16	0.30	0.35	T2	SMT5	2000
THROUGH HOLE									pp. 6-7	p. 10	
PE-64102	1:1	1-2/4-5/7-8	75	2.1	3.0	10	0.20	0.20	T2	TH4	500
PE-64107	1:1	1-2/4-5/7-8	75	2.4	3.5	10	0.25	0.30	T2	TH2	2000
PE-64502	1:1	1-2/4-5/7-8	75	2.1	3.0	10	0.20	0.20	T2	TH4	2000
PE-64103	1:1	1-2/4-5/7-8	100	2.1	3.0	10	0.20	0.30	T2	TH4	500
PE-64108	1:1	1-2/4-5/7-8	100	2.1	3.5	10	0.25	0.40	T2	TH2	2000
PE-64503	1:1	1-2/4-5/7-8	100	2.1	3.0	10	0.20	0.30	T2	TH4	2000
PE-64104	1:1	1-2/4-5/7-8	150	2.1	3.5	12	0.20	0.30	T2	TH4	500
PE-64109	1:1	1-2/4-5/7-8	150	3.0	3.0	15	0.20	0.45	T2	TH2	2000

NOTES:

1. OCL, C_{ww} and L_L are measured at 20 mVrms, 100 KHz.
2. Rise time is measured in 75 Ω systems.
3. To order Tape & Reel packaging for surface mount parts, add the suffix "T" to the part number. Example: PE-65723T. The "T" will appear on all paper work, but will not be marked on parts.

Typical Application Circuit

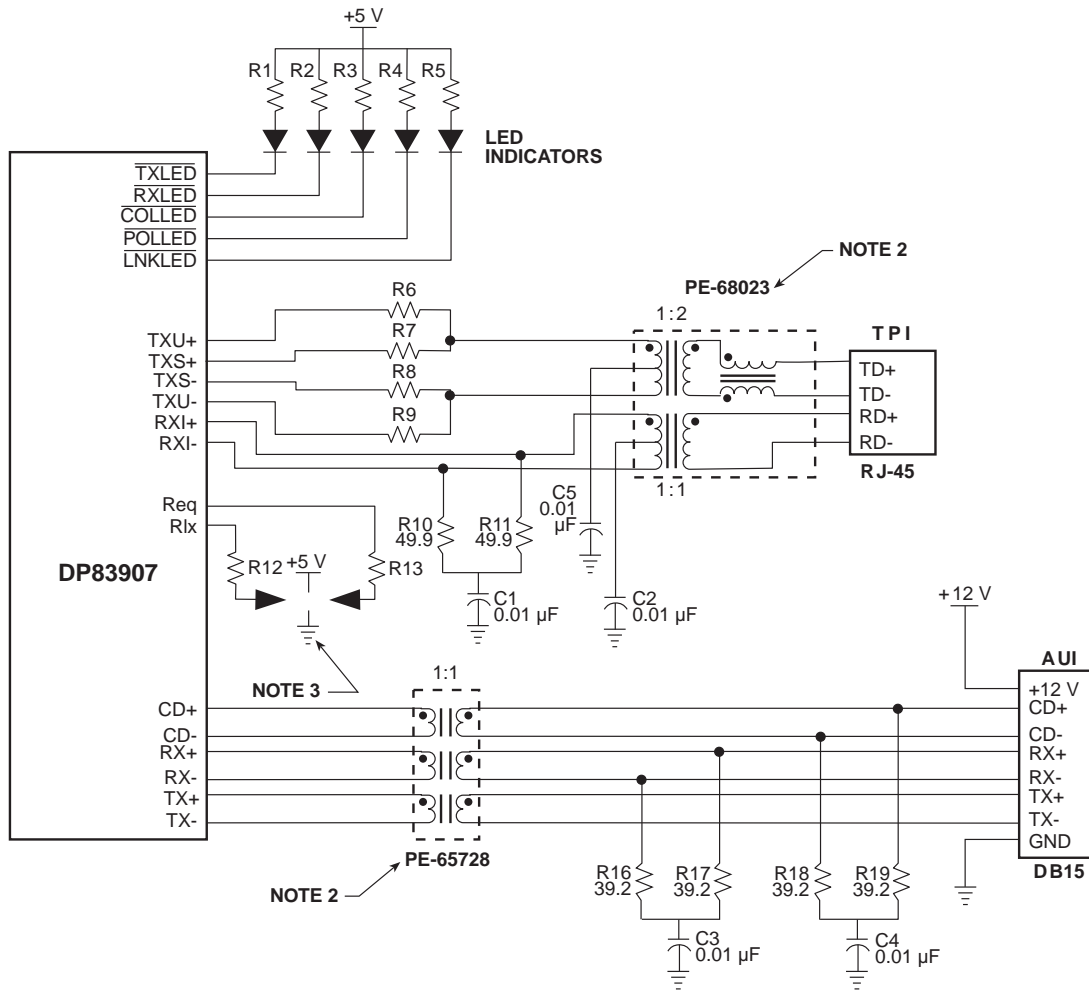

NOTES:

1. Connections at pins 12 and 13 apply to PE-68023 only. These are test points. **Do not ground.**
2. For specific information, see pages 2 and 3 in this catalog.
3. For specific connection, refer to National's Application Notes.

Typical 10Base-T Application Circuit

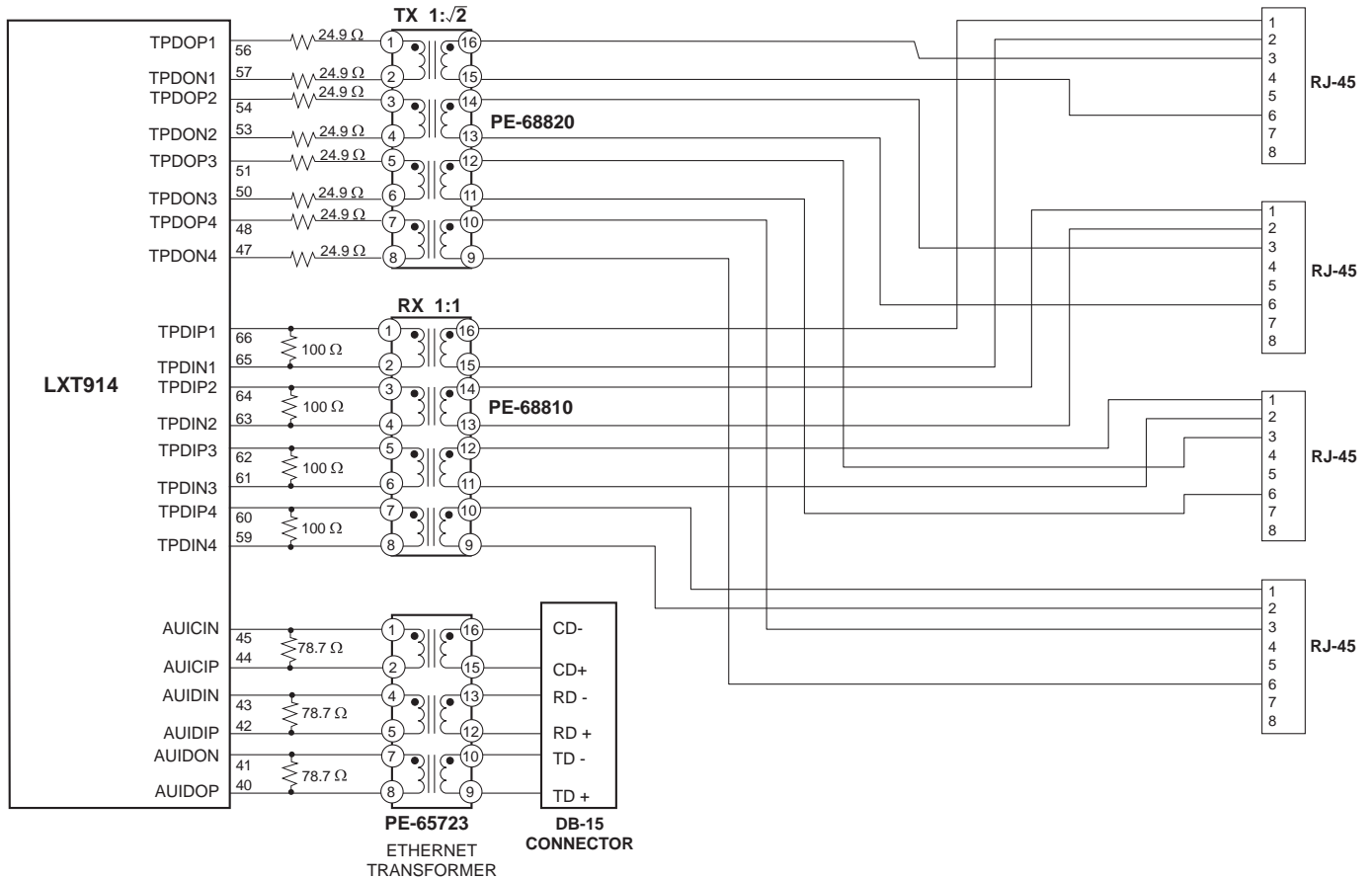

Schematics

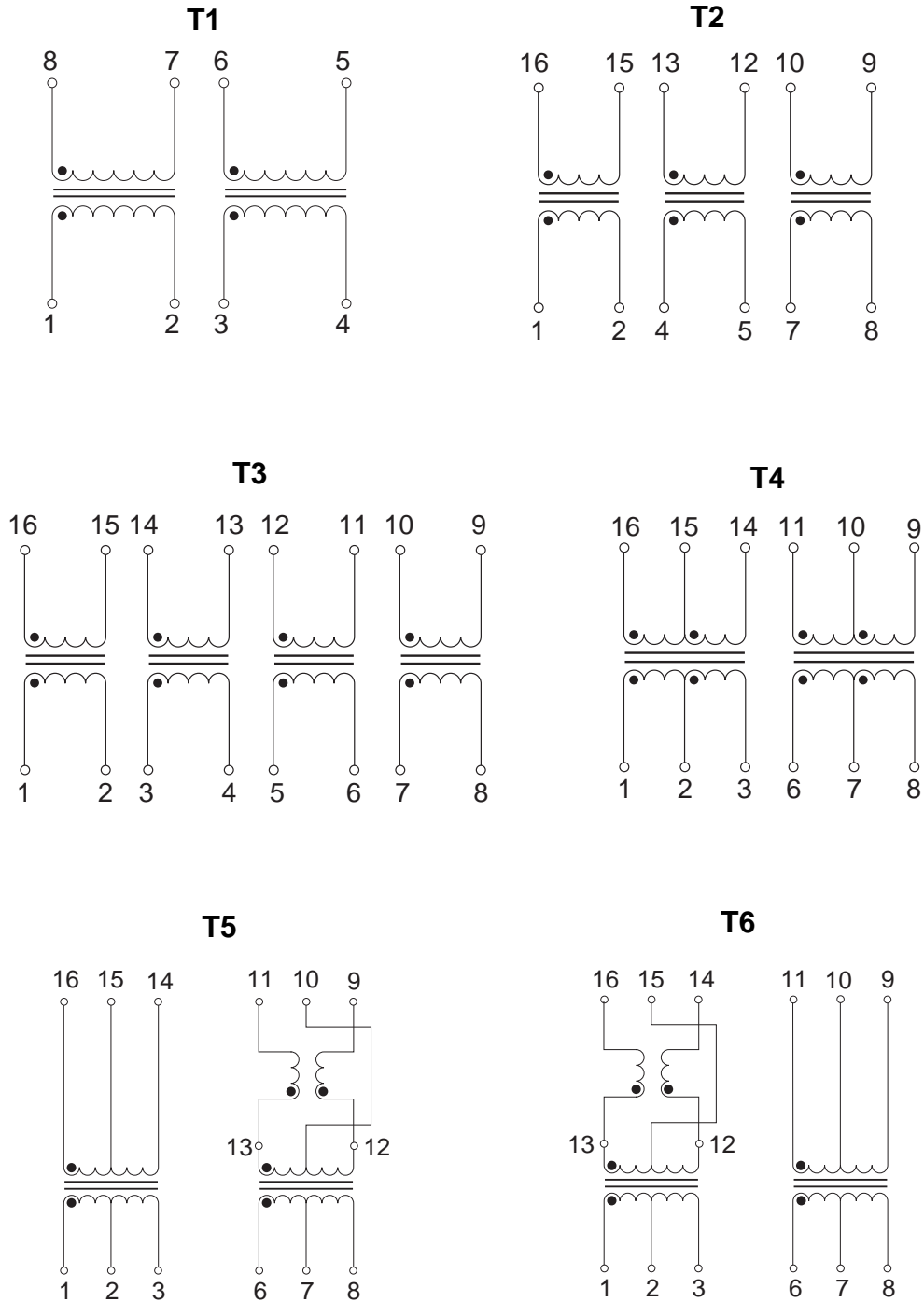

Schematics (continued)

T7

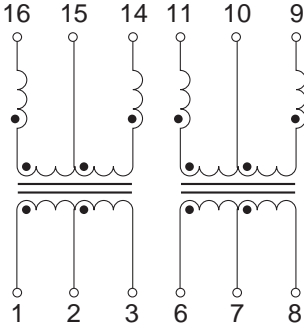

T8

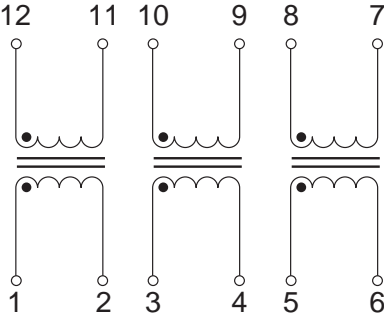

T9

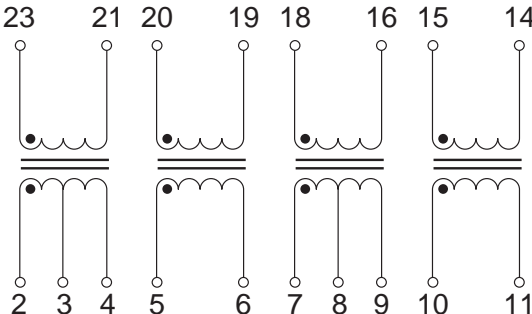

Surface Mount Mechanicals

SMT1

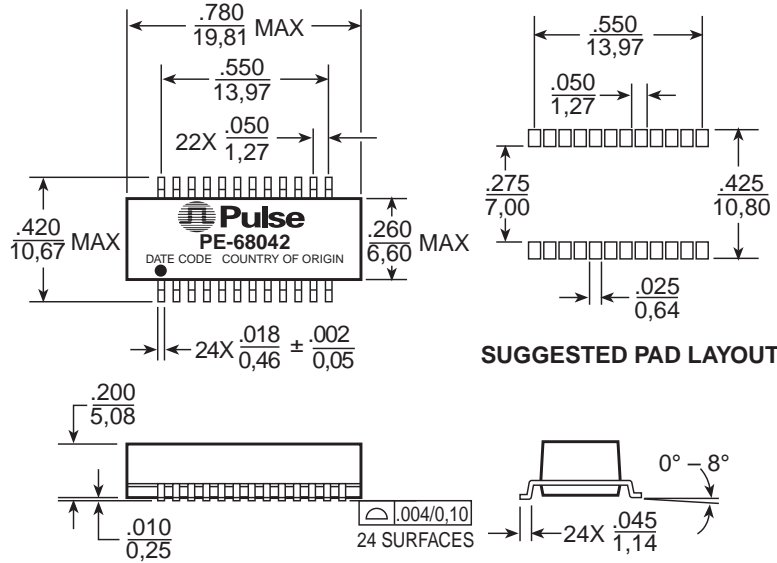

Dimensions: $\frac{\text{Inches}}{\text{mm}}$
 Unless otherwise specified,
 all tolerances are $\pm .010$
 $\frac{0,25}{0,25}$

Weight1.15 grams
Tube25/tube
Tape & Reel350/reel

SMT2

SMT3

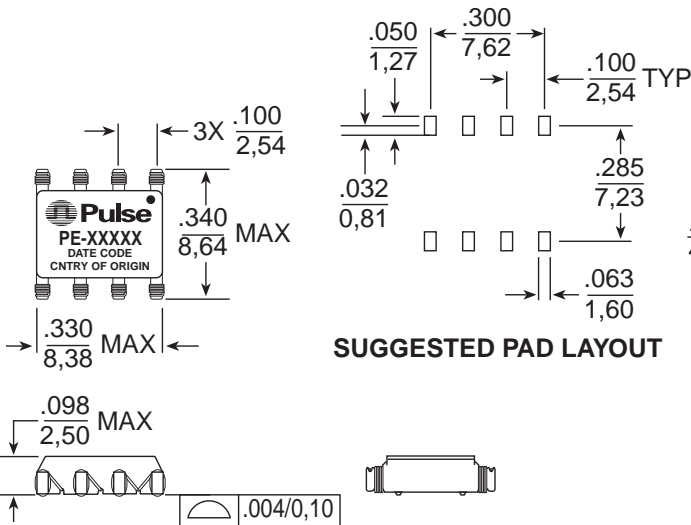

SUGGESTED PAD LAYOUT

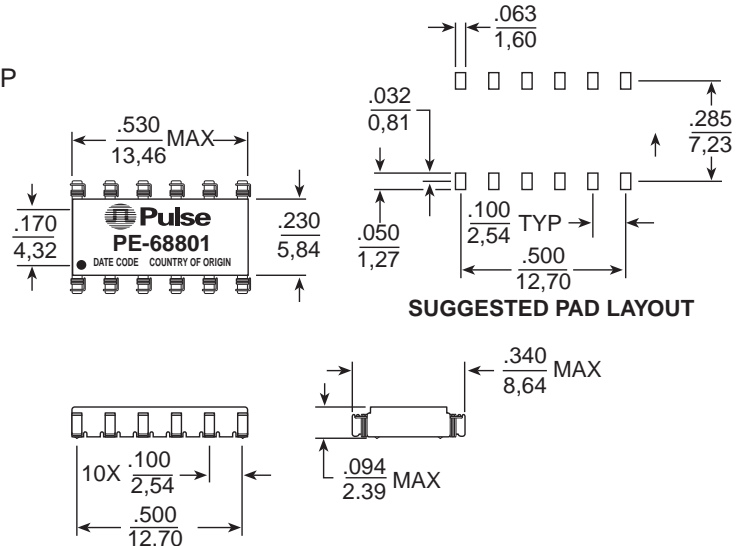

SUGGESTED PAD LAYOUT

Weight0.22 grams
Tube60/tube
Tape & Reel1500/reel

Dimensions: $\frac{\text{Inches}}{\text{mm}}$ Unless otherwise specified, all tolerances are $\pm .010$
 $\frac{0,25}{0,25}$

Weight0.28 grams
Tube35/tube
Tape & Reel1500/reel

Surface Mount Mechanicals (continued)

SMT4

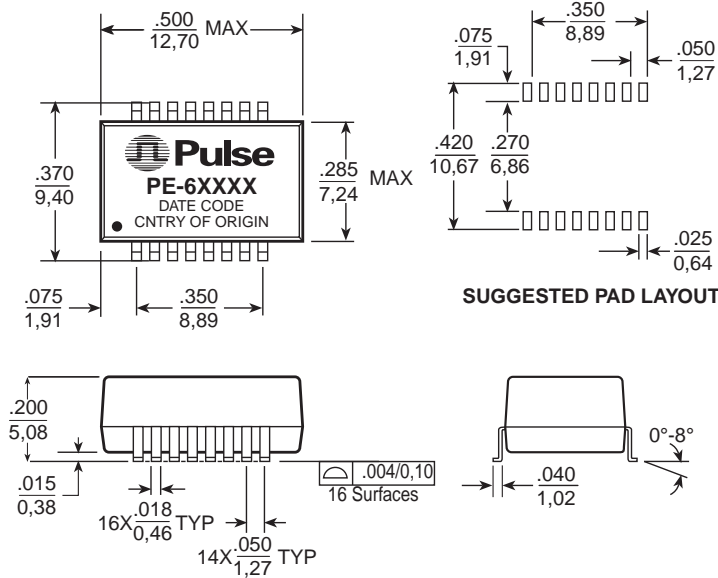

Dimensions: $\frac{\text{Inches}}{\text{mm}}$

Unless otherwise specified, all tolerances are $\pm \frac{.010}{0,25}$

Weight0.82 grams

Tube40/tube

Tape & Reel900/reel

SMT5

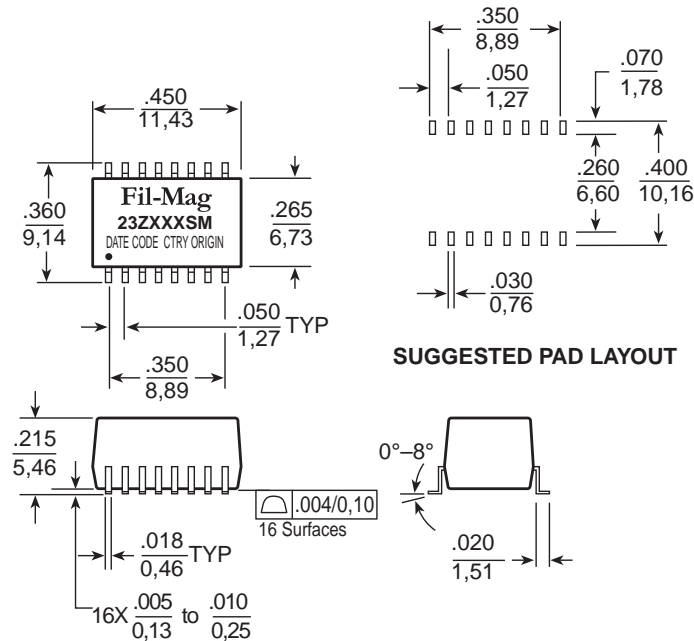

Dimensions: $\frac{\text{Inches}}{\text{mm}}$

Unless otherwise specified, all tolerances are $\pm \frac{.005}{0,13}$

Weight0.85 grams

Tube50/tube

Tape & Reel750/reel

Through Hole Mechanicals

TH1

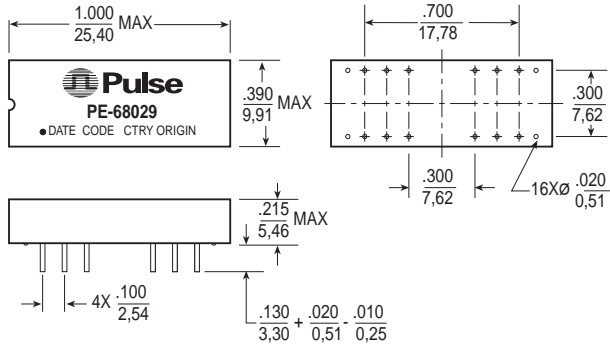

Dimensions: $\frac{\text{Inches}}{\text{mm}}$

Unless otherwise specified, all tolerances are $\pm \frac{.010}{0,25}$

Weight 2.17 grams

Tube20/tube

TH2

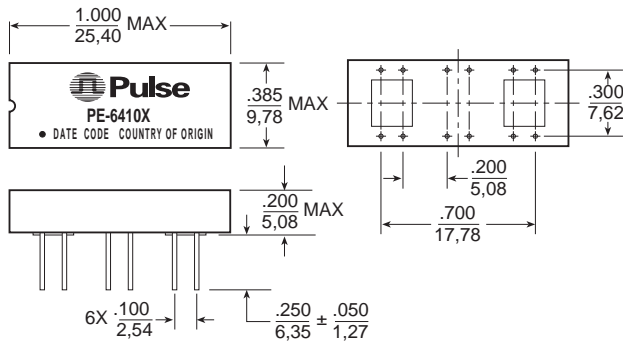

Dimensions: $\frac{\text{Inches}}{\text{mm}}$

Unless otherwise specified, all tolerances are $\pm \frac{.010}{0,25}$

Weight 2.18 grams

Tube20/tube

TH3

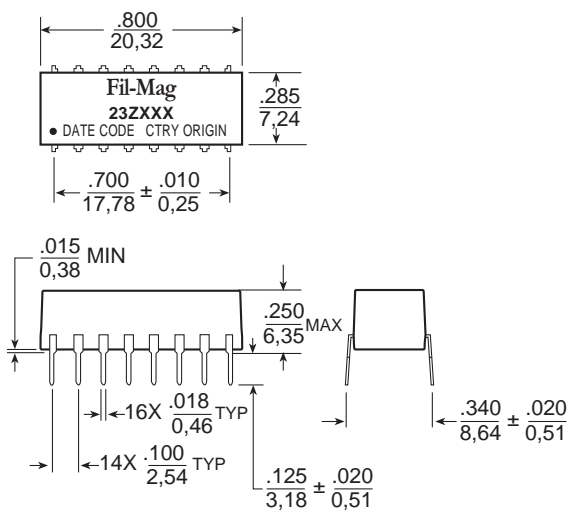

Dimensions: $\frac{\text{Inches}}{\text{mm}}$

Unless otherwise specified, all tolerances are $\pm \frac{.005}{0,13}$

Weight 1.7 grams

Tube28/tube

TH4

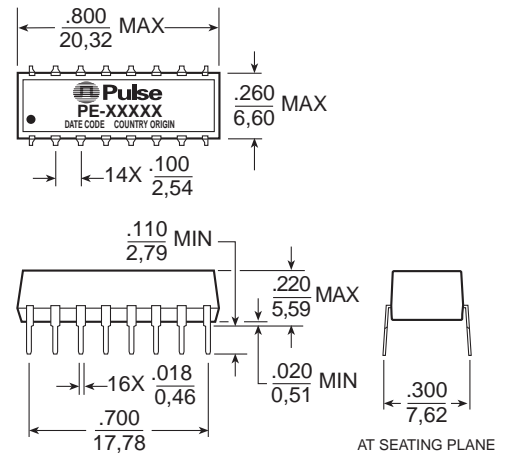

Part Number

Weight (Grams)

Tube

PE-64101/PE-64102/PE-64103
 PE-64104/PE-64502/PE-64503
 PE-65263

1.22

25

Dimensions: $\frac{\text{Inches}}{\text{mm}}$

Unless otherwise specified, all tolerances are $\pm \frac{.010}{0,25}$

For More Information :

Corporate

12220 World Trade Drive
 San Diego, CA 92128
 Tel: 619 674 8100
 FAX: 619 674 8262
 http://www.pulseeng.com
 Quick-Facts: 619 674 9672

Europe

Millpool House
 Mill Lane, Godalming
 Surrey GU7 1EY
 U.K.
 Tel: 441 483 428 877
 FAX: 441 483 416 011

Asia

P.O. Box 26-11, KEPZ
 6 Central Sixth Road
 KEPZ, Kaohsiung
 Taiwan, R.O.C.
 Tel: 886 7 821 3141
 FAX: 886 7 841 9707

Distributor

Performance warranty of products offered on this data sheet is limited to the parameters specified. Data is subject to change without notice. Other brand and product names mentioned herein may be trademarks or registered trademarks of their respective owners.