

Enhanced RS-232 Line Drivers/Receivers

- Operates from Single 5V Power Supply
- Meets All RS-232D and V.28 Specifications
- Multiple Drivers and Receivers
- Small Charge Pump Capacitors – 0.1 μ F
- Operates with 0.1 μ F and 100 μ F Capacitors
- High Data Rate – 120kbps Under Load
- High Output Slew Rate – 10V/ μ s Under Load
- Low Power Shutdown $\leq 1\mu$ A
- 3-State TTL/CMOS Receiver Outputs
- ± 30 V Receiver Input Levels
- Low Power CMOS – 15mA Operation



DESCRIPTION...

The **Sipex SP231A**, **SP232A** and **SP233A** are enhanced versions of the **Sipex SP231**, **SP232** and **SP233** RS-232 line drivers/receivers. They are pin-for-pin replacements for these earlier versions and will operate in their sockets. Performance enhancements include 10V/ μ s slew rate, 120k bits per second guaranteed transmission rate, and increased drive current for longer and more flexible cable configurations. Ease of use enhancements include smaller, 0.1 μ F charge pump capacitors, enhanced ESD protection, low power dissipation and overall ruggedized construction for commercial environments. The series is available in plastic and ceramic DIP and SOIC packages operating over the commercial, industrial and military temperature ranges.

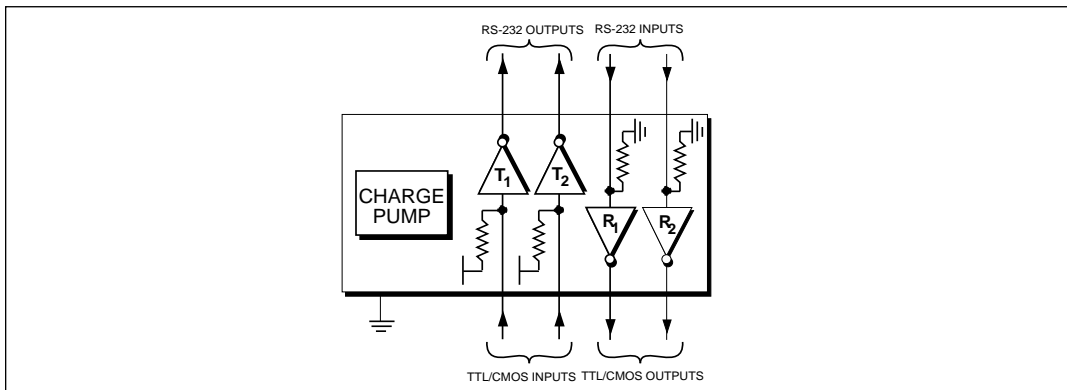

ABSOLUTE MAXIMUM RATINGS

This is a stress rating only and functional operation of the device at these or any other conditions above those indicated in the operation sections of this specification is not implied. Exposure to absolute maximum rating conditions for extended periods of time may affect reliability.

V _{CC}	+6V
V ⁺	(V _{CC} -0.3V) to +13.2V
V ⁻	-13.2V
Input Voltages		
T _{IN}	-0.3 to (V _{CC} +0.3V)
R _{IN}	±30V

Output Voltages

T _{OUT}	(V ⁺ , +0.3V) to (V ⁻ , -0.3V)
R _{OUT}	-0.3V to (V _{CC} +0.3V)
Short Circuit Duration		
T _{OUT}	Continuous
Power Dissipation		
CERDIP	675mW (derate 9.5mW/°C above +70°C)
Plastic DIP	375mW (derate 7mW/°C above +70°C)
Small Outline	375mW (derate 7mW/°C above +70°C)

SPECIFICATIONS

V_{CC}=+5V±10%; V⁺=+8.5V to +13.2V (SP231A only) 0.1μF charge pump capacitors; T_{MIN} to T_{MAX} unless otherwise noted.

PARAMETERS	MIN.	TYP.	MAX.	UNITS	CONDITIONS
TTL INPUT					
Logic Threshold			0.8	Volts	T _{IN} ; \overline{EN} , \overline{SD} T _{IN} ; \overline{EN} , \overline{SD} T _{IN} = 0V C _L = 2500pF, R _L = 3kΩ
LOW	2.0			Volts	
HIGH		15	200	μA	
Logic Pullup Current				kbps	
Maximum Data Rate	120				
TTL OUTPUT					
TTL/CMOS Output			0.4	Volts	I _{OUT} = 3.2mA; V _{CC} = +5V I _{OUT} = -1.0mA $\overline{EN} = V_{CC}$, 0V ≤ V _{OUT} ≤ V _{CC}
Voltage, Low	3.5			Volts	
Voltage, High		0.05	±10	μA	
Leakage Current **; T _A = +25°					
RS-232 OUTPUT					
Output Voltage Swing	±5	±9		Volts	All transmitter outputs loaded with 3kΩ to Ground V _{CC} = 0V; V _{OUT} = ±2V Infinite duration
Output Resistance	300			Ohms	
Output Short Circuit Current		±18		mA	
RS-232 INPUT					
Voltage Range	-30		+30	Volts	V _{CC} = 5V, T _A = +25°C V _{CC} = 5V, T _A = +25°C V _{CC} = 5V, T _A = +25°C T _A = +25°C, -15V ≤ V _{IN} ≤ +15V
Voltage Threshold					
LOW	0.8	1.2		Volts	
HIGH		1.7	2.4	Volts	
Hysteresis	0.2	0.5	1.0	Volts	
Resistance	3	5	7	kΩ	
DYNAMIC CHARACTERISTICS					
Propagation Delay, RS232 to TTL		1.5		μs	C _L = 10pF, R _L = 3-7kΩ; T _A = +25°C C _L = 2500pF, R _L = 3kΩ; measured from +3V to -3V or -3V to +3V SP310A and SP312A only SP310A and SP312A only
Instantaneous Slew Rate			30	V/μs	
Transition Region Slew Rate		10		V/μs	
Output Enable Time **		400		ns	SP310A and SP312A only SP310A and SP312A only
Output Disable Time **		250		ns	
POWER REQUIREMENTS					
V _{CC} Power Supply Current		10 25	15	mA mA	No load, T _A = +25°C; V _{CC} = 5V All transmitters R _L = 3kΩ; T _A = +25°C No load, V ⁺ = 12V, T _A = +25°C V _{CC} = 5V, T _A = +25°C
V ⁺ Power Supply Current ***		9	15	mA	
Shutdown Supply Current **		1	10	μA	

SP310A and SP312A only; * SP231A only

PERFORMANCE CURVES

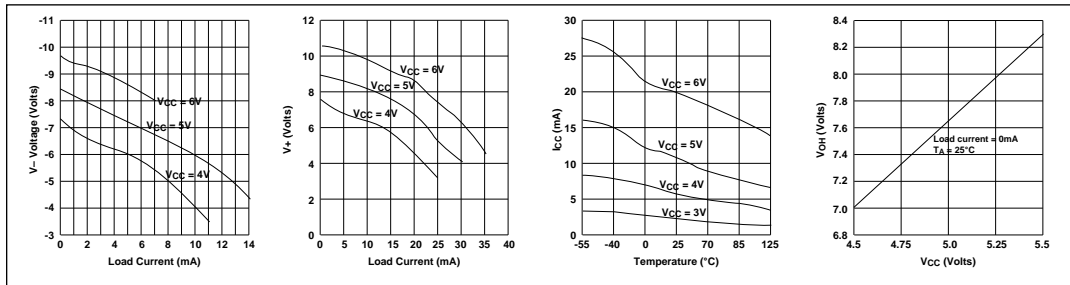

PINOUT...

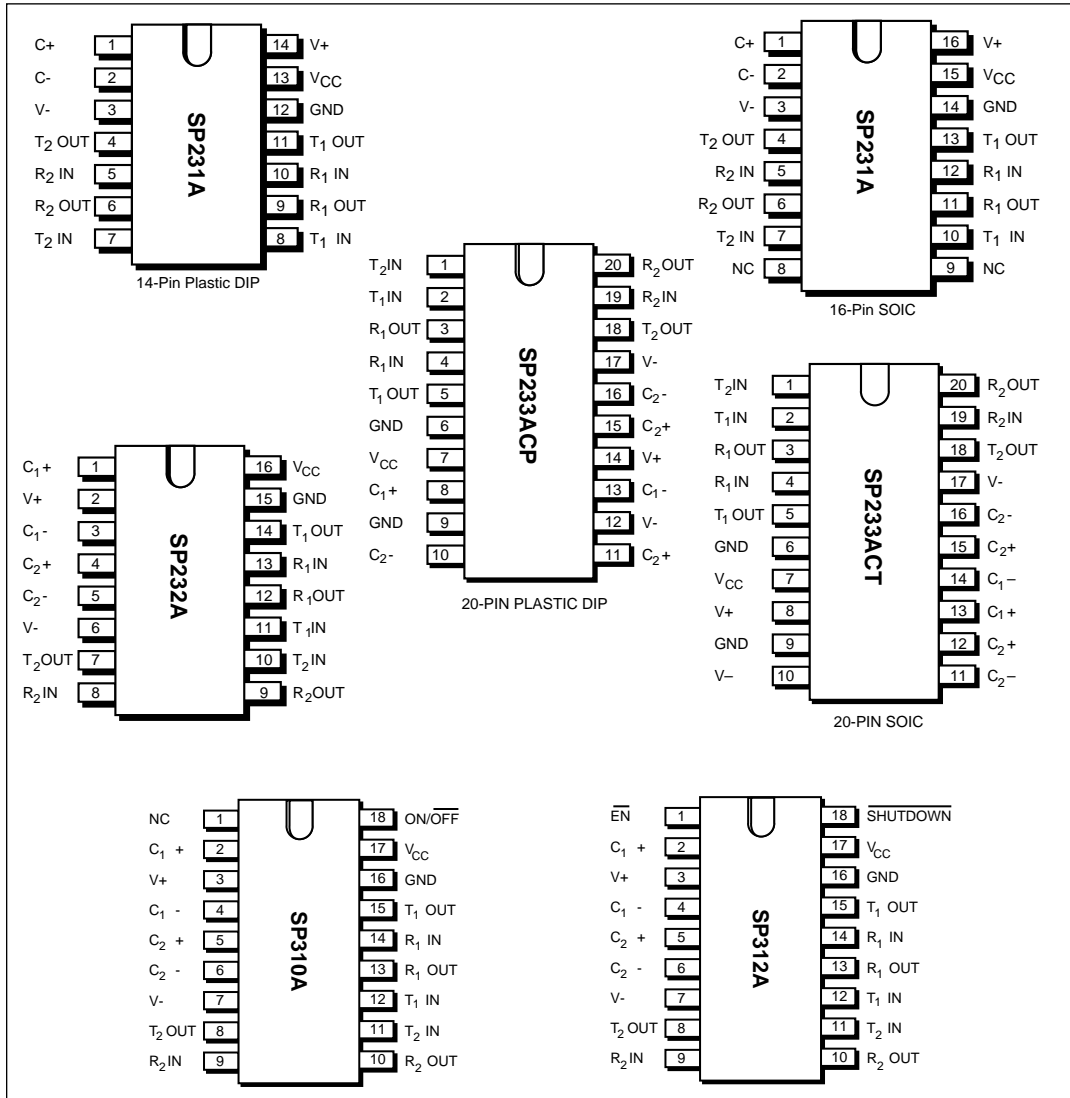

FEATURES...

The **Sipex SP231A**, **SP232A** and **SP233A** are enhanced versions of the **Sipex SP231**, **SP232** and **SP233** RS-232 line drivers/receivers. They are pin-for-pin replacements for these earlier versions, will operate in their sockets with capacitors ranging from 0.1 to 100 μ F, either polarized or non-polarized, and feature several improvements in both performance and ease of use. Performance enhancements include 10V/ μ s slew rate, 120k bits per second guaranteed transmission rate, and increased drive current for longer and more flexible cable configurations. Ease of use enhancements include smaller, 0.1 μ F charge pump capacitors, enhanced ESD protection, low power dissipation and overall ruggedized construction for commercial environments.

The **SP232A**, **SP233A**, **SP310A** and **SP312A** include charge pump voltage converters which allow them to operate from a single +5V supply. These converters convert the +5V input power to the \pm 10V needed to generate the RS-232 output levels. Both meet all EIA RS-232D and CCITT V.28 specifications. The **SP231A** has provisions for external V+ supplies. With this power supplied externally, the current drain due to charge pump operation is considerably reduced, typically to 400 μ A.

The **SP310A** provides identical features as the **SP232A**. The **SP310A** has a single control line which simultaneously shuts down the internal DC/DC converter and puts all transmitter and receiver outputs into a high impedance state. The **SP312A** is identical to the **SP310A** with separate tri-state and shutdown control lines.

The **SP231A** is available in 14-pin plastic DIP, Cerdip and 16-pin SOIC packages for operation over commercial, industrial and military temperature ranges. The **SP232A** is available in 16-pin plastic DIP, SOIC and Cerdip pack-

ages, operating over the commercial, industrial and military temperature ranges. The **SP233A** is available in a 20-pin plastic DIP and 20-pin SOIC package for operation over the commercial and industrial temperature ranges. The **SP310A** and **SP312A** are available in 18-pin plastic, Cerdip and SOIC packages for operation over the commercial and industrial temperature ranges. Please consult the factory for DIP and surface-mount packaged parts supplied on tape-on-reel, as well as parts screened to MIL-M-38510.

THEORY OF OPERATION

The **SP231A**, **SP232A**, **SP233A**, **SP310A** and **SP312A** devices are made up of three basic circuit blocks – 1) a driver/transmitter, 2) a receiver and 3) a charge pump. Each block is described below.

Driver/Transmitter

The drivers are inverting transmitters, which accept TTL or CMOS inputs and output the RS-232 signals with an inverted sense relative to the input logic levels. Typically the RS-232 output voltage swing is \pm 9V. Even under worst case loading conditions of 3kOhms and 2500pF, the output is guaranteed to be \pm 5V, which is consistent with the RS-232 standard specifications. The transmitter outputs are protected against infinite short-circuits to ground without degradation in reliability.

The instantaneous slew rate of the transmitter output is internally limited to a maximum of 30V/ μ s in order to meet the standards [EIA RS-232-D 2.1.7, Paragraph (5)]. However, the transition region slew rate of these enhanced products is typically 10V/ μ s. The smooth transition of the loaded output from V_{OL} to V_{OH} clearly meets the monotonicity requirements of the standard [EIA RS-232-D 2.1.7, Paragraphs (1) & (2)].

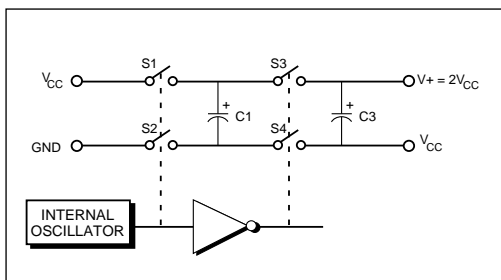

Figure 1. Charge Pump Voltage Doubler

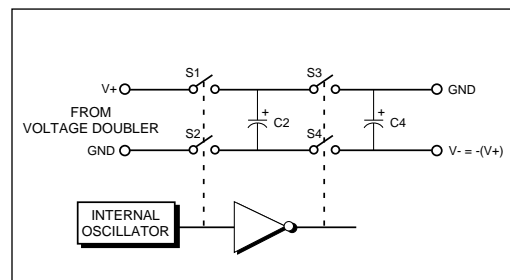

Figure 2. Charge Pump Voltage Inverter

Receivers

The receivers convert RS-232 input signals to inverted TTL signals. Since the input is usually from a transmission line, where long cable lengths and system interference can degrade the signal, the inputs have a typical hysteresis margin of 500mV. This ensures that the receiver is virtually immune to noisy transmission lines.

The input thresholds are 0.8V minimum and 2.4V maximum, again well within the $\pm 3V$ RS-232 requirements. The receiver inputs are also protected against voltages up to $\pm 30V$. Should an input be left unconnected, a 5kOhm pulldown resistor to ground will commit the output of the receiver to a high state.

In actual system applications, it is quite possible for signals to be applied to the receiver inputs before power is applied to the receiver circuitry. This occurs, for example, when a PC user attempts to print, only to realize the printer wasn't turned on. In this case an RS-232 signal from the PC will appear on the receiver input at the printer. When the printer power is turned on, the receiver will operate normally. All of these enhanced devices are fully protected.

Charge Pump

The charge pump section of these devices allows the circuit to operate from a single +5V $\pm 10\%$ power supply by generating the required operating voltages internal to the devices. The charge pump consists of two sections — 1) a voltage doubler and 2) a voltage inverter.

As shown in *Figure 1*, an internal oscillator triggers the charge accumulation and voltage inversion. The voltage doubler momentarily stores a charge on capacitor C_1 equal to V_{CC} , referenced to ground. During the next transition of the oscillator this charge is boot-strapped to transfer charge to capacitor C_3 . The voltage across C_3 is now from V_{CC} to V^+ .

In the inverter section (*Figure 2*), the voltage across C_3 is transferred to C_2 forcing a range of 0V to V^+ across C_2 . Boot-strapping of C_2 will then transfer charge to C_4 to generate V^- .

One of the significant enhancements over previous products of this type is that the values of the capacitors are no longer critical and have been decreased in size considerably to 0.1 μF . Because the charge pump runs at a much higher frequency, the 0.1 μF capacitors are sufficient to transfer and sustain charges to the two transmitters.

APPLICATION HINTS

Protection From Shorts to $\pm 15V$

The driver outputs are protected against shorts to ground, other driver outputs, and V^+ or V^- . If the possibility exists that the outputs could be inadvertently connected to voltages higher than $\pm 15V$, then it is recommended that external protection be provided. For protection against voltages exceeding $\pm 15V$, two back-to-back zener diodes connected from each output to ground will clamp the outputs to an acceptable voltage level.

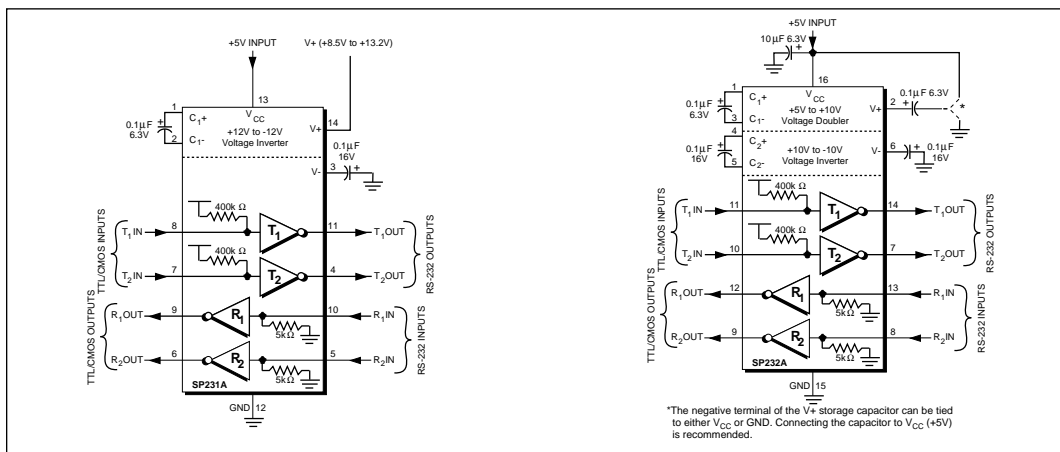

Figure 3. Typical Circuits using the SP231A and 232A.

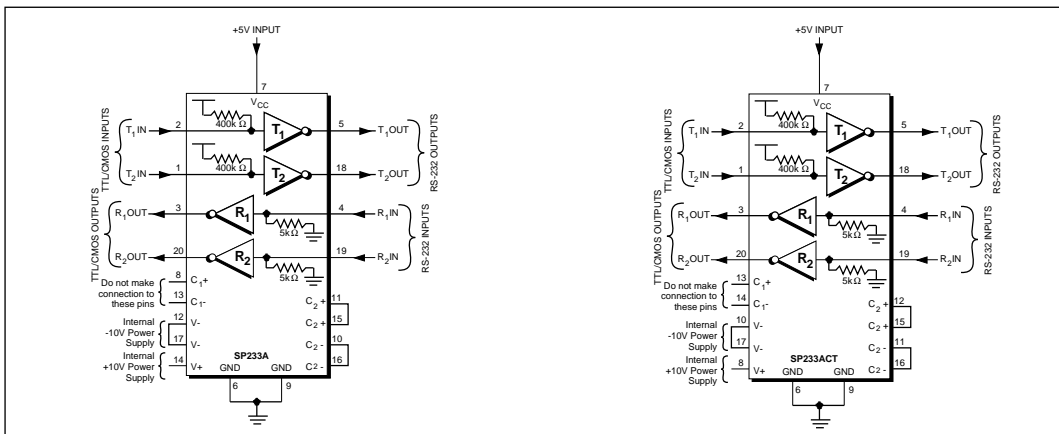

Figure 4. Typical Circuits using the SP233ACP and SP233ACT

Shutdown (\overline{SD}) and Enable (\overline{EN}) SP310A/SP312A Only

Both the SP310A and SP312A have a shut-down/standby mode to conserve power in battery-powered systems. To activate the shutdown mode, which stops the operation of the charge pump, a logic "0" is applied to the appropriate control line. For the SP310A, this control line is $\overline{ON/OFF}$ (pin 18). Activating the shutdown mode also puts the SP310A transmitter and receiver outputs in a high impedance condition (tri-stated). The shutdown mode is controlled on the SP312A by a logic "0" on the $\overline{SHUTDOWN}$ control line (pin 18); this also puts the transmitter outputs in a tri-state mode. The receiver outputs can be tri-stated separately during normal operation or shutdown by a logic "1" on the \overline{ENABLE} line (pin 1).

Wake-Up Feature (SP312A Only)

The SP312A has a wake-up feature that keeps all the receivers in an enabled state when the device is in the shutdown mode. Table 1 defines the truth table for the wake-up function.

With only the receivers activated, the SP312A typically draws less than 5 μ A supply current (10 μ A maximum). In the case of a modem interfaced to a computer in power down mode, the Ring Indicator (RI) signal from the modem would be used to "wake up" the computer, allowing it to accept data transmission.

After the ring indicator signal has propagated through the SP312A receiver, it can be used to

trigger the power management circuitry of the computer to power up the microprocessor, and bring the SD pin of the SP312A to a logic high, taking it out of the shutdown mode. The receiver propagation delay is typically 1 μ s. The enable time for V⁺ and V⁻ is typically 2ms. After V⁺ and V⁻ have settled to their final values, a signal can be sent back to the modem on the data terminal ready (DTR) pin signifying that the computer is ready to accept and transmit data.

Pin Strapping — SP233ACT Only

The SP233A packaged in the 20-pin SOIC package (SP233ACT) has a slightly different pinout than the SP233A in other package configurations. To operate properly, the following pairs of pins must be externally wired together:

- the two V⁻ pins (pins 10 and 17)
- the two C₂⁺ pins (pins 12 and 15)
- the two C₂⁻ pins (pins 11 and 16)

All other connections, features, functions and performance are identical to the SP233A as specified elsewhere in this data sheet.

\overline{SD}	\overline{EN}	Power Up/Down	Receiver Outputs
1	0	Down	Enable
1	1	Down	Tri-state
0	0	Up	Enable
0	1	Up	Tri-state

Table 1. Wake-up Function Truth Table.

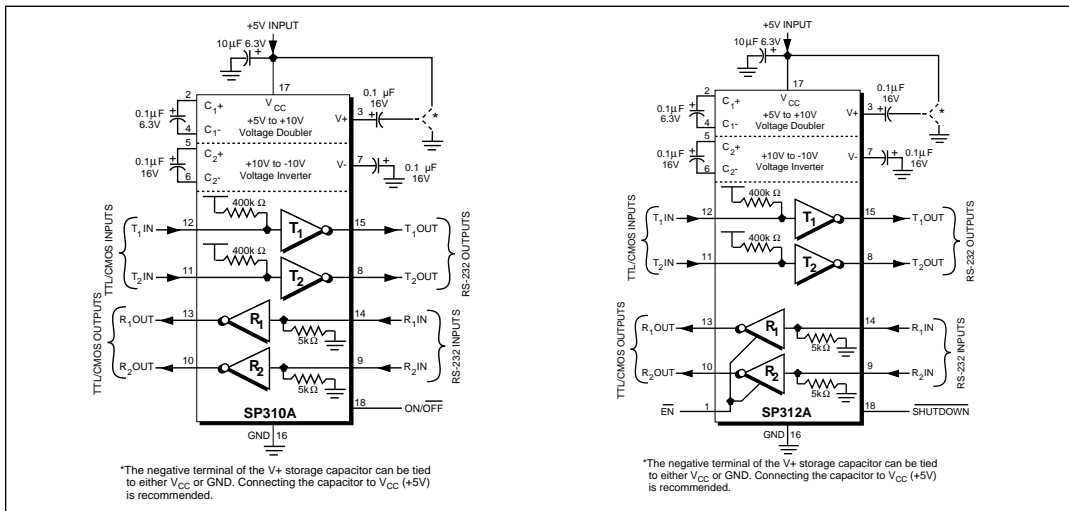

Figure 5. Typical Circuits using the SP310A and SP312A

ORDERING INFORMATION

Model	Temperature Range	Package
SP231ACP	0°C to +70°C	14-pin Plastic DIP
SP231ACT	0°C to +70°C	16-pin SOIC
SP231ACX	0°C to +70°C	Dice
SP231AEP	-40°C to +85°C	14-pin Plastic DIP
SP231AET	-40°C to +85°C	16-pin SOIC
SP232ACN	0°C to +70°C	16-pin N-SOIC
SP232ACP	0°C to +70°C	16-pin Plastic DIP
SP232ACT	0°C to +70°C	16-pin SOIC
SP232ACX	0°C to +70°C	Dice
SP232AEN	-40°C to +85°C	16-pin N-SOIC
SP232AEP	-40°C to +85°C	16-pin Plastic DIP
SP232AET	-40°C to +85°C	16-pin SOIC
SP233ACP	0°C to +70°C	20-pin Plastic DIP
SP233ACT	0°C to +70°C	20-pin SOIC
SP233AEP	-40°C to +85°C	20-pin Plastic DIP
SP233AET	-40°C to +85°C	20-pin SOIC
SP310ACP	0°C to +70°C	18-pin Plastic DIP
SP310ACT	0°C to +70°C	18-pin SOIC
SP310ACX	0°C to +70°C	Dice
SP310AEP	-40°C to +85°C	18-pin Plastic DIP
SP310AET	-40°C to +85°C	18-pin SOIC
SP312ACP	0°C to +70°C	18-pin Plastic DIP
SP312ACT	0°C to +70°C	18-pin SOIC
SP312ACX	0°C to +70°C	Dice
SP312AEP	-40°C to +85°C	18-pin Plastic DIP
SP312AET	-40°C to +85°C	18-pin SOIC

CT and ET packages available Tape-on-Reel. Please consult the factory for pricing and availability for this option, and for parts screened to MIL-STD-883.

THIS PAGE LEFT INTENTIONALLY BLANK