

## Arm® Cortex®-A53/-R5F/-M4F, Lattice ECP5™

Designed for industrial communication or time-critical

The phyCORE-AM64x-FPGA is a robust and reliable headless embedded solution especially for time-critical industrial systems. The 70 mm x 39 mm SOM has an extensive 400-pin interconnect that supports common communication protocols such as CAN, EtherCAT®, UART, I<sup>2</sup>C, but also automation-specific interfaces such as ePWM, eCAP and eQEP, as well as 92 universal FPGA-I/Os. Due to the heterogeneous architecture of the TI AM64x processor and the Lattice ECP5 FPGA, you can run the majority of your application under Linux and outsource critical components to the specialized

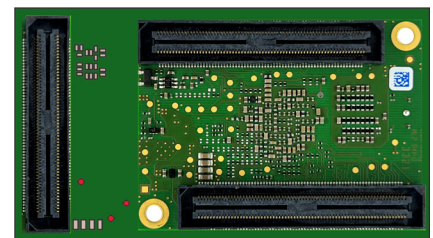
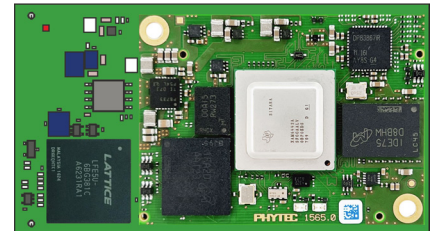

### Highlights

- Single- or dual-core Arm® Cortex®-A53 (up to 1 GHz)
- Up to 4x Cortex®-R5F cores (up to 800 MHz) for real-time processing
- 1x isolated Cortex®-M4F MCU (up to 400 MHz) for general purposes, safety and critical tasks
- Lattice ECP5™ FPGA, 44 k LUTs, 72 18x18 Multiplier, 108x 18 kbit sysMEM Blocks, 1944 kbit EB-RAM
- QSPI Flash as configuration memory, writable by the CPU
- 4x PRU-ICSSG industrial Ethernet interfaces, usable with different communication protocol stacks (TSN, EtherCAT®, PROFINET®, EtherNet/IP™ and others)
- No additional license costs for industrial protocol stacks
- ePWM, eCAP and eQEP supported
- DDR4 with inline ECC
- Single +3.3 V supply voltage for simplification of the base board design



[www.phytec.eu/en/phycore-am64x-](http://www.phytec.eu/en/phycore-am64x-)

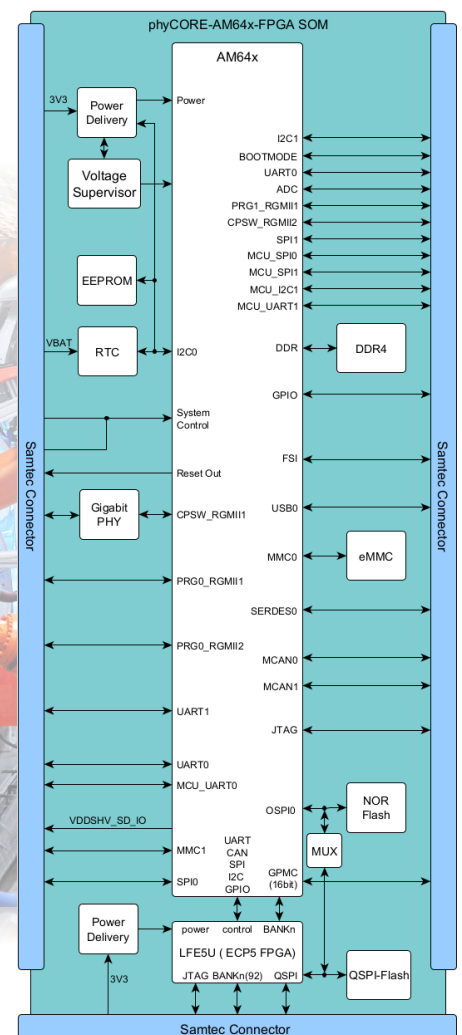

# Technical Data (preliminary)

## Module Configuration

SOC	
Processor	TI AM6411, TI AM6412, TI AM6424, TI AM6441, TI AM6442, TI AM2431, TI AM2432, TI AM2434
Core	up to 4x Arm® Cortex®-A53
Coprocessor	Arm® Cortex®-R5F, Arm® Cortex®-M4F
Clock frequency	up to 1 GHz (Arm Cortex-A53)
L2 Cache	256 kB L2 with ECC
Internal RAM	2 MB SRAM with ECC
HW Security	3DES, AES, DRBG, MD-5, PKA, SHA-1, SHA-2
EXT. MEMORY	
eMMC	4 GB up to 32 GB
DDR4	1 GB default up to 2 GB
NOR Flash	64 MB up to 256 MB (Octal SPI/Dual SPI Flash)
EEPROM	4 KB
FPGA	
FPGA	Lattice ECP5 LFE5U-45
LTUs	44 k
Programmierbare I/Os	92 (LVTTTL / LVDS)
sysDSP™	54-bit ALU, 72 18x18 Multipliers
sysMEM™	108 x 18 kbit
Embedded Speicher	1944 kbit
Configuration memory	16 MB QSPI Flash
PHYSICAL PROPERTIES	
Dimensions	70 mm x 39 mm x 7.6 mm

MAXIMUM INTERFACES*, **	
Ethernet	2x Gigabit (1x on-board PHY / 1x RGMII), 4x Gigabit Industrial (PRU-ICSSG)
USB	1x 2.0 Dual Role, 1x 3.1 Dual Role
UART	up to 9
CAN	2x CAN FD
PCI / PCIe	1x PCIe 2.0
I²C	up to 6
SPI	up to 7
MMC/SD/SDIO	up to 2
PWM	up to 9
GPMC	yes
A/D	up to 8
Debugging	JTAG
FPGA-I/O	92x

\* Due to multiplexing, not all interfaces may be fully available.  
 \*\* Due to the exclusive use of individual interfaces on the module, the maximum number may differ from the processor specification.

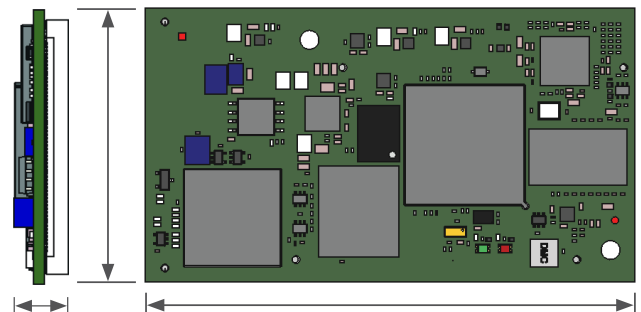

## phyBOARD®-Electra

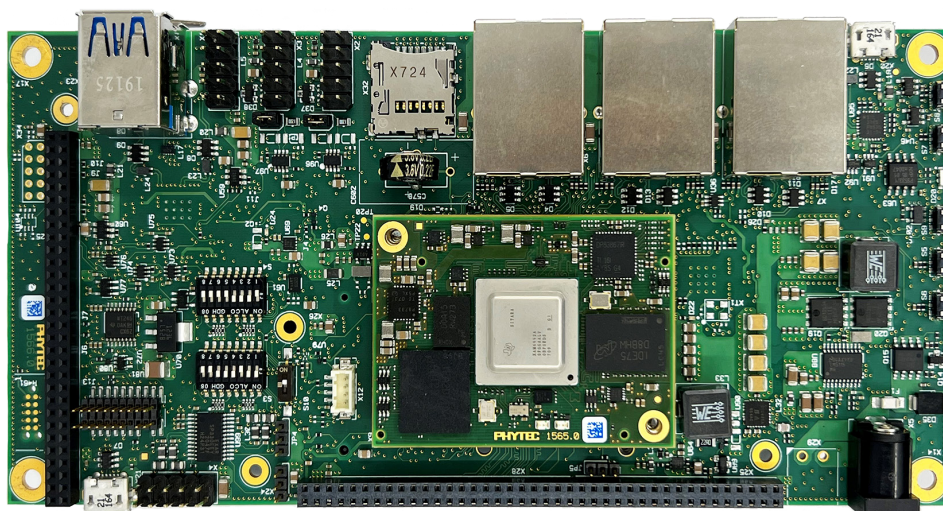

INTERFACES	
Ethernet	3x 10/100/1000BASE-T (TSN support)
USB	1x USB 2.0 OTG (Micro-AB) 2x USB 3.0 host (Type-A)
Serial	1x RS-232 or RS-485; 1x FSI, 2x CAN FD (4x pin header 2x5)
PCI / PCIe	1x PCIe 2.0 (Mini PCIe)
Debugging	JTAG (pin header), XDS110 (Micro-AB)
Various	I²C, SPI, A/D, GPIO (Expansion sockets)
MISCELLANEOUS	
MMC/SD/SDIO	microSD Card Slot